

RWL600 Series LED Roadway Lighting

LED Driver Electrical and Dimming Control Specification 30-70Watt



| | |
|---|---|
| Input Voltage: 100~277VAC 47~63Hz Optional 200~480VAC | DC Output: 240VDC / Constant Current |
| Input Inrush Current: < 10A / 100VAC, < 20A / 277VAC | Operation Temp: -40° ~ 50°C / -40° ~ 122°F |
| Power Factor: > 0.92 at Full Load, 115VAC, 230VAC | Storage Temp: -40° ~ 80°C / -40° ~ 176°F |
| Current Crest Factor (Ipk): 1A Max | Safety Meet: UL8750 Class 2, IEC60598-2-1, CE, RoHS |
| Total Harmonic Distortion: 15% Max | Meet: EN55015, EN61547, EN61347-2-13, EN6100-3-2, |
| Driver Efficiency: ≥98% | EN61000-3-3, FCC Class B |
| Protection OCP, SCP, OVP - Auto Recovery | Surge Protection: 6kV / 3kA |

NOTE: All Values Have ±7% Tolerance

Wiring Information

- AC LINE - BLACK
- AC NEUTRAL - WHITE

NOTE: • Ensure that all line voltage wire is intended for specified product wattage.
• Use UL and/or CE approved wires for all input connections, minimum size required 18 AWG (0.82mm²)

WARNING

RISK OF ELECTRIC SHOCK

- Installation must be done by a certified electrician and / or qualified personnel.
- Make sure to turn OFF the main power from the circuit breaker or fuse box before installing, servicing or inspecting this luminaire.
- Make sure all grounding wires are connected correctly.

RWL600 Series LED Roadway Lighting

LED Driver Electrical and Dimming Control Specification 30-70Watt

Wiring & Application Diagram

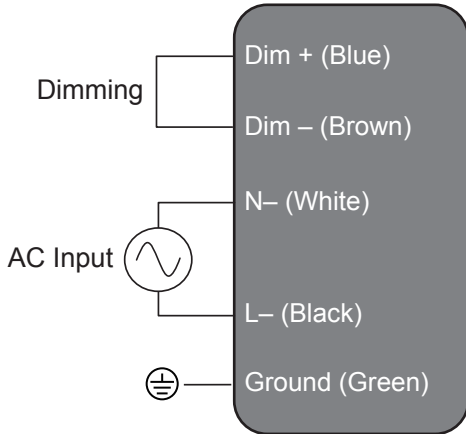

- NOTE:**
- Ensure that all line voltage wire is intended for specified product wattage.
 - Use UL and / or CE approved wires for all input connections, minimum size required 18 AWG (0.82mm²)
 - Refer to the specific dimmer installation manual for exact wiring instructions.

WARNING

RISK OF ELECTRIC SHOCK

- Installation must be done by a certified electrician and / or qualified personnel.
- Make sure to turn OFF the main power from the circuit breaker or fuse box before installing, servicing or inspecting this luminaire.
- Make sure all grounding wires are connected correctly.

RWL600 Series LED Roadway Lighting

LED Driver Electrical and Dimming Control Specification 30-70Watt

Output Dimming Control

The method to dim the output current of the driver is done via the +Dim/-Dim Signal pins. The +Dim/-Dim Signal pins respond to a 1 to 10 V signal, delivering 10% to 100% of the output current based on rated current for each model. A pull-up resistor is included internal to the driver. When the +Dim input is <1 V or short circuited to the -Dim wire (Brown) or to the -LED wire (black), the output current is programmed to 10% of rated current. If the +Dim input is >10V or open circuited, the output current shall be programmed to 100% of rated current. The maximum current supplied by the +Dim Signal pin is < 600 μ A.

The following graph shows the relationship of the output current to the dimming input voltage.

